

Pozicija	Kol.	Opis
	1	<p>SOLOLIFT2 WC-3</p>  <p style="text-align: center;">Opozorilo! Slika proizvoda je simboli na</p> <p>Št. proizvoda: 97775315</p> <p>Sololift2 WC-3 is a small, compact automatic lifting station suitable for pumping of wastewater off places in private dwellings where wastewater cannot be led directly to the sewer by means of a natural downward slope.</p> <p>Sololift2 WC-3 is suitable for pumping wastewater from a toilet containing toilet paper and faeces with additional connections on the lid and to the sides of the tank for e.g. washbasin, shower or bidet.</p> <p>The pumping of liquids containing other material may cause faults and limit the scope of guarantee.</p> <p>Sololift2 WC-3 is typically used to dewater:</p> <ul style="list-style-type: none">• toilet, washbasin, shower and bidet in basements below sewer level, in connection with the renovation or modernisation of existing buildings, where the location may be remote from the main soil pipe so that a natural slope cannot be established. <p>Extremely low switching levels for lowest construction heights, advantageously in case of connection of a shower receptor.</p> <p>The compact lifting station is equipped with</p> <ul style="list-style-type: none">- Cable with or without plug (see technical data)- Horizontal or vertical fastening possibility of discharge hose connector with several adaptors for pipes with Ø22-40mm <p>-Integrated non return valve</p> <ul style="list-style-type: none">- Dry and high performance motor unit incl. thermal protection, pressure switch and controller- DN100 toilet connection hose- Two flexible connectors for inlet (adjustable in height) of pipes Ø36 or 40- Slot for an alarm board with buzzer (accessory)- Manual anti clogging function and separate drain connection for service- Venting valve with overflow protection- Uplift fixation clips <p>Design according to EN12050-3 and production inspection by external institute with unique features focused on quick installation, long lasting operation and easy clean service.</p> <p>Note: The discharge adaptor can be mounted vertical or horizontal. Vertical installation increase the flow (s. databooklet and curves)</p> <p>Teko ina:</p> <p>Maks. temp. medija: 50 °C</p> <p>Specifi na teža: 998.2 kg/m3</p> <p>Tehni ni podatki:</p> <p>Odobritve na napisni tablici: CE,TR,LGA,VDEEMV,VDE</p> <p>Toleranca krivulje: ISO9906:2012 3B</p>

Pozicija	Kol.	Opis
		Materiali: Posoda: PLASTIC
		Montaža: Sesalni priključek rpalke: 32/36/40, 36/40/50, DN 100 Tla ni priključek rpalke: 22/25/28/32/36/40 Št. vodnikov: 3X0,75MM2
		Električni podatki: Vhodna moč - P1: 620 W Omrežna frekvenca: 50 Hz Nominalna napetost: 1 x 220-240 V Nominalni tok: 3 A Cos phi - faktor moči: 0,92 Nominalna hitrost: 2800 rpm Razred zaščite (IEC 34-5): IP44 Izolacijski razred (IEC 85): F Dolžina kabla: 1.2 m Tip kabla: H05VV-F Tip kablanskega priključka: SCHUKO
		Drugo: Neto teža: 7.3 kg Bruto teža: 10 kg

97775315 SOLOLIFT2 WC-3 50 Hz

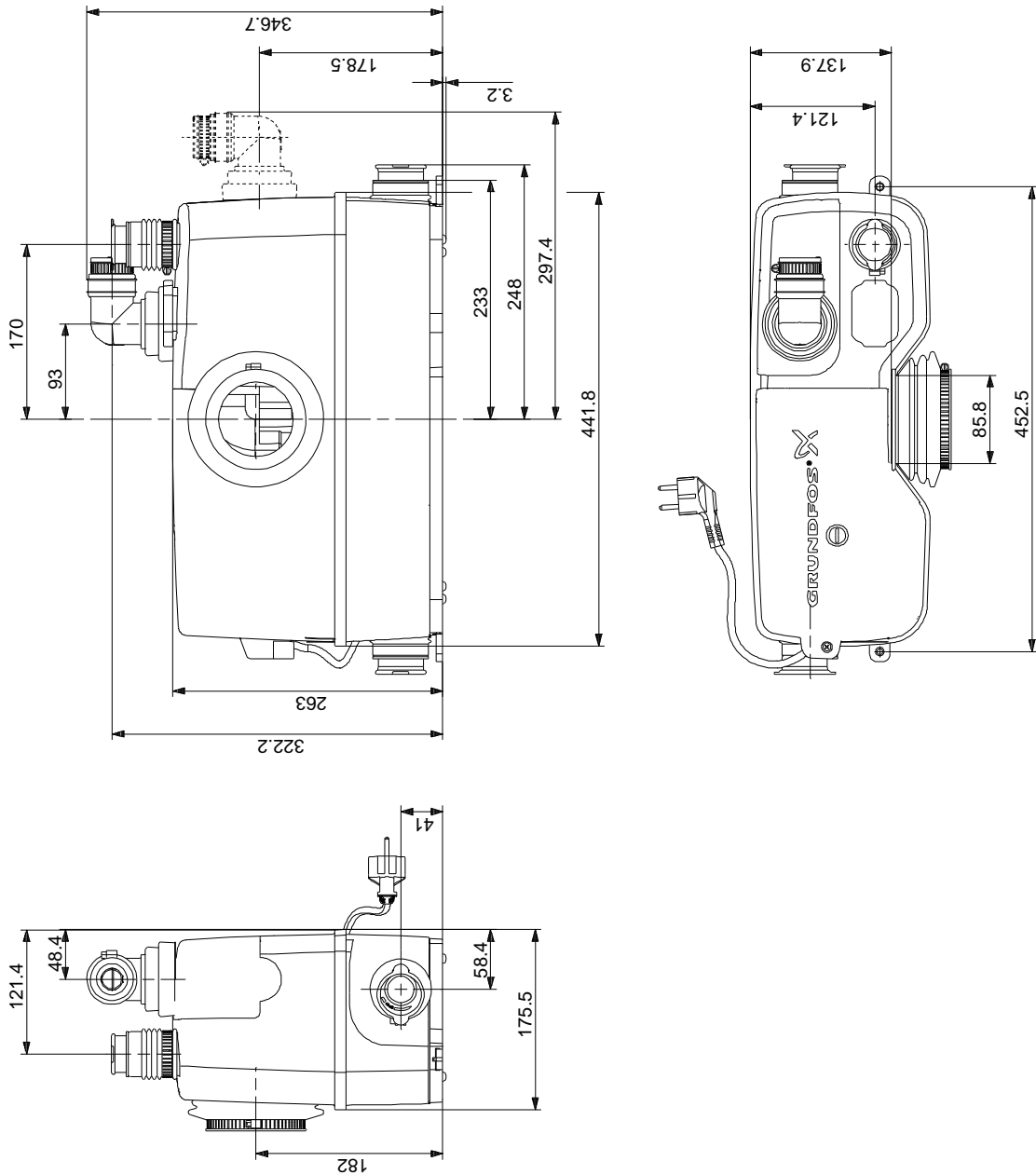

Opozorilo! Vse enote so v [mm], razen če je navedeno.
To poenostavljeno dimenzioniranje ne kaže vseh detajlov.