

# POLAR MULTIAIR



\_In ceramica.  
\_In ceramic.  
\_En céramique.  
\_Aus Keramikbausatz.  
\_De cerámica.

109\_Sand

<b>POWER max</b>	11,5 - 9.890 [kW-kcal/h]
<b>POWER min</b>	3,3 - 2.838 [kW-kcal/h]
	90,8 [%]
	52 [l]
	pellet Ø 6-8 x 5÷30 [mm]
	~ 0,6 / ~ 2,1 [kg/h]
	~ 56 / ~ 17 [h]
	245/40 - 280/35 - 330/30 [m³]
	8 [cm]
	190 [kg]
	10 - 0,10 [Pa- mbar]
	180 [°C]
	min. 2,3 - max 8,3 [g/s]



ART. 15a B-VG  
BAFA gefördert

EN 14785  
REGENSBURGER / MÜNCHENER BS1B  
BlmSchV

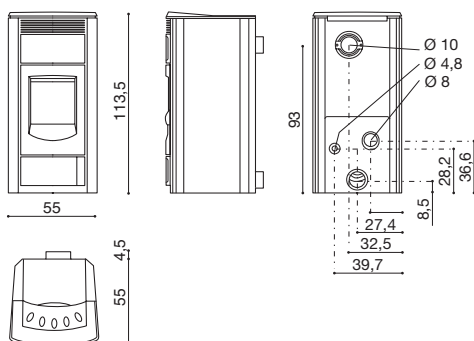

110\_Salt and pepper



106\_Desert



105\_Bordeaux

