

CONFLUO PREMIUM “SLIM LINE“



PEŠTAN CONFLUO PREMIUM DRAIN “ SLIM LINE “

Peštan Confluo Premium SLIM LINE drain made from polipropilen with ABS made grid holder, with no side inlets and one horizontal DN 50mm output, minimum installation height of 72mm and flow rate of 48 l/min. Base of drain without socket with water sealing height of 25 mm, with height adjustable reducer for linear drain and feet for height and inclination adjustment and with hair stopper. Stainless steel plate and stainless steel grate class K3 (up to 300 kg of load), with set for fine ceramic leveling from 5mm up to 20mm.

IMPORTANT TECHNICAL INFORMATION	
Minimal installation height	72mm
Lengths (numbers represent length of the grid)	450mm , 550mm , 650mm , 750mm , 850mm , 950mm , 1050mm , 1150mm
Width of grid carrier/mask/grid	20mm/100mm
Flow (in accordance with EN1253)	48 l/min
Output	Ø50mm
The height of the water plug	25mm
Maximum height of ceramics within the grid and the grid	5mm-20mm
Load class of the grid (in accordance with EN 1253)	K3 - withstands 300 kg pressure
Grid material	Stainless steel AISI 304 (optimal AISI 316)
Drain body material	ABS (grid carrier)/PP (reducer, base)

DRAIN ADVANTAGES:

- a) Base rotation 360°
- b) Low installation height 72mm
- c) Output Ø50
- d) Ultra slim design of the grid
- e) Easy installation and maintenance



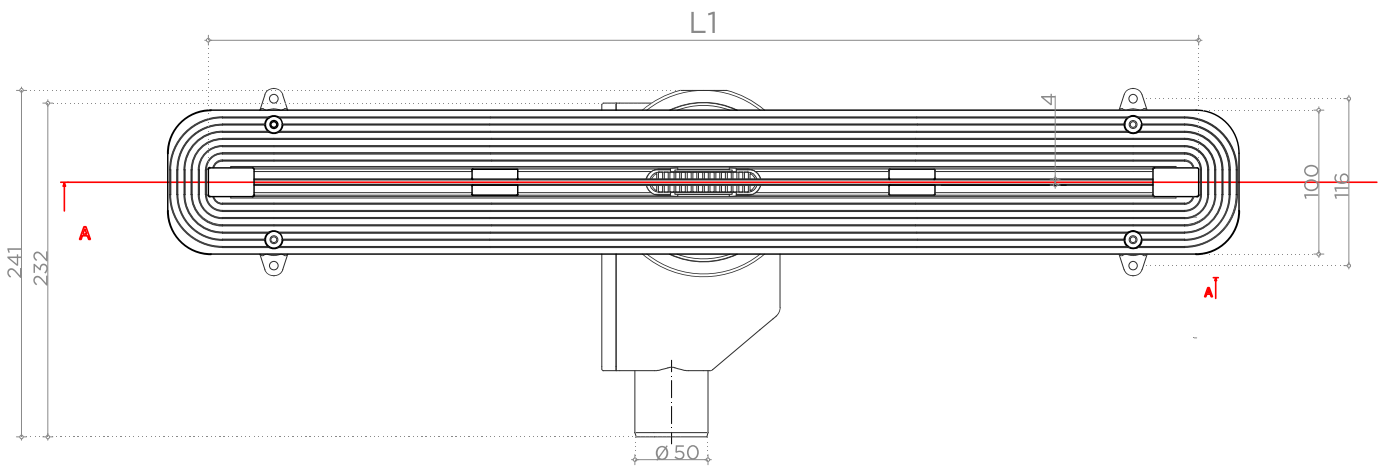
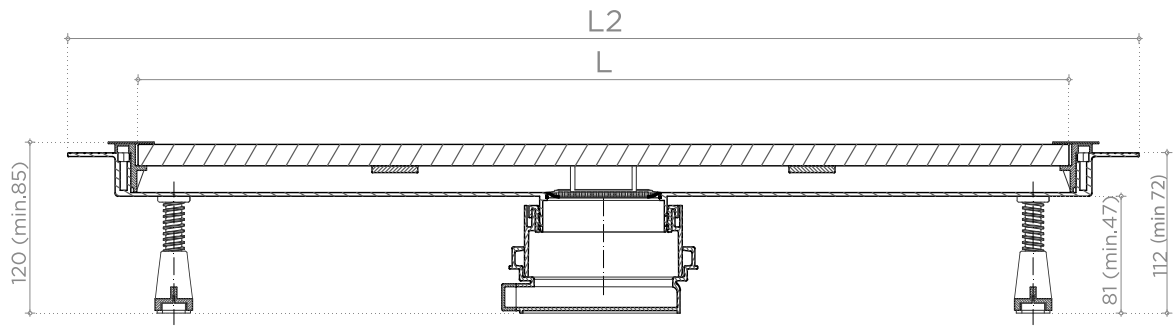

NOTE: Drains in length of 300,450 i 550 come in package with two sets of legs for adjusting of height. Drains in length 650,750 i 850 come in package with four sets of legs for adjusting of height.

L mm	450	550	650	750	850	950	1050	1150
L1 mm	492	592	692	792	892	1092	1192	1292
L2 mm	548	648	748	848	948	1048	1148	1248



Code	Name	Weight	Box dimensions
13100031	Confluo premium drain "slim line 450"	1,567 kg	674mm x 170mm x 130mm
13100032	Confluo premium drain "slim line 550"	1,766 kg	674mm x 170mm x 130mm
13100033	Confluo premium drain "slim line 650"	1,868 kg	960mm x 170mm x 130mm
13100034	Confluo premium drain "slim line 750"	1,935 kg	960mm x 170mm x 130mm
13100035	Confluo premium drain "slim line 850"	2,137 kg	960mm x 170mm x 130mm
13100036	Confluo premium drain "slim line 950"	2,232 kg	1263mm x 170mm x 130mm
13100037	Confluo premium drain "slim line 1050"	2,333 kg	1263mm x 170mm x 130mm
13100038	Confluo premium drain "slim line 1150"	2,429 kg	1263mm x 170mm x 130mm

